

# Original Mounting and Operating Instructions

## Electrical Process Heater Electrical Flange Heater

BVS 11 ATEX E161 U  
II 2 G Ex d IIC Gb

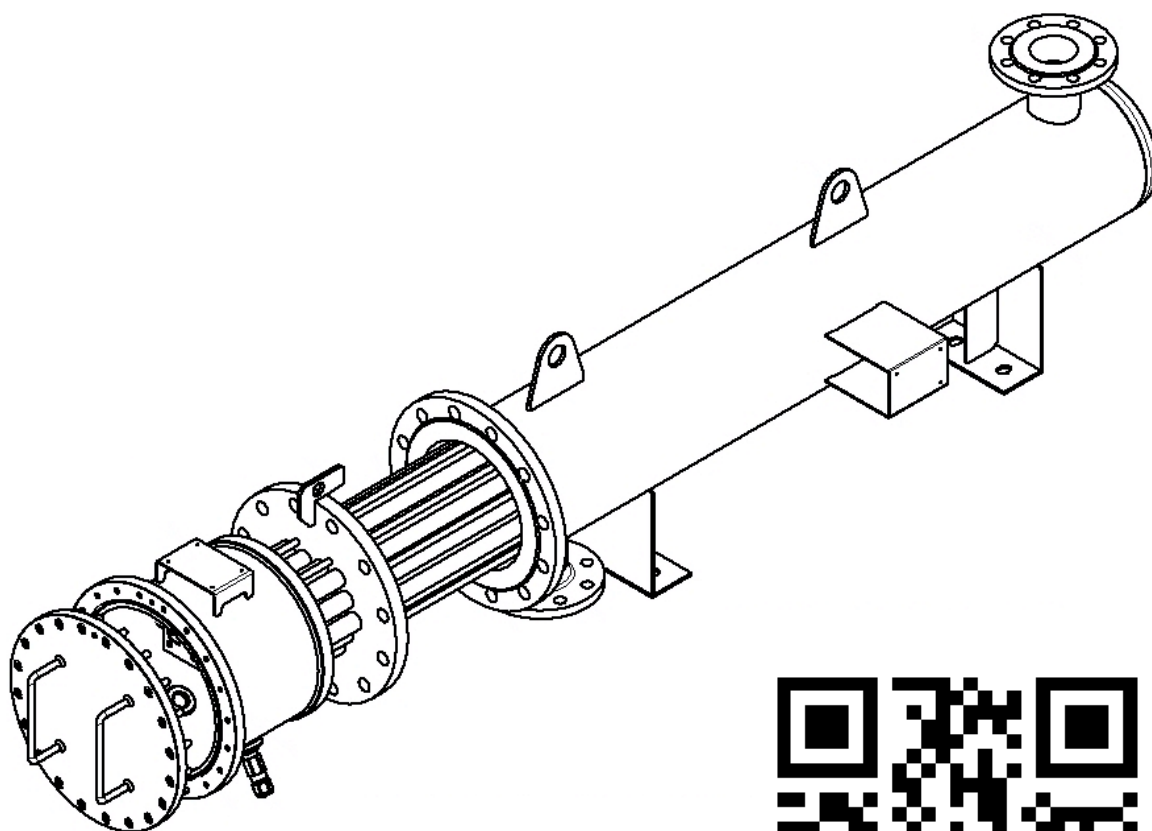

## Table of Contents

1.1	Information on these operating instructions .....	4
1.2	Explanation of the symbols.....	5
1.3	Warnings .....	6
1.4	Limitations of liability .....	8
1.5	Copyright .....	9
1.6	Manufacturer's data .....	9
1.7	Customer service .....	9
<b>2</b>	<b>Safety .....</b>	<b>10</b>
2.1	Proper use.....	11
2.2	Plant operator's responsibility .....	12
2.3	Other applicable standards and regulations .....	13
2.4	Prohibition of reconstructions .....	13
2.5	General safety information.....	14
2.6	Special dangers.....	15
2.6.1	Operation in hazardous areas.....	15
2.6.2	Danger by electricity.....	16
2.6.3	Danger of burring.....	16
2.6.4	Danger by pressurized plant sections .....	17
2.7	Safety devices .....	18
2.8	Requirements for the personnel .....	19
2.9	Personal protective equipment.....	20
<b>3</b>	<b>Technical data .....</b>	<b>21</b>
3.1	Storage conditions .....	21
<b>4</b>	<b>Structure and function.....</b>	<b>22</b>
4.1	Electrical flange heater.....	22
4.2	Electrical process heater.....	26
4.3	Scope of delivery .....	27
<b>5</b>	<b>Transport, packing and storage .....</b>	<b>28</b>
5.1	Transport inspection .....	28
5.2	Packaging .....	29
5.3	Storage .....	29
5.4	Handling during transport.....	30
<b>6</b>	<b>Installation .....</b>	<b>31</b>
6.1	Safety information.....	31
6.2	Requirements for the installation site.....	31
6.3	Mounting the electrical flange heater.....	34
6.4	Montage Elektro-Durchlauferhitzer .....	35
6.5	Important information on the electrical connection.....	36
6.6	Mounting the housing cover .....	38
<b>7</b>	<b>Commissioning.....</b>	<b>39</b>
7.1	Setting/checking the operating points .....	40

7.2	Test run .....	41
7.3	Adjusting the overheating protection.....	41
<b>8</b>	<b>Maintenance/revision .....</b>	<b>42</b>
8.1	Removing the flange heater .....	43
8.2	Removing deposits.....	44
8.3	Reinstalling the flange heater .....	44
8.4	Replacing components .....	45
	8.4.1 Stockkeeping of spare parts .....	45
	8.4.2 Replacing the temperature sensors, temperature limiters .....	45
	8.4.3 Replacing the wiring/connecting terminals .....	45
<b>9</b>	<b>Elimination of faults .....</b>	<b>46</b>
<b>10</b>	<b>Disassembly and disposal .....</b>	<b>49</b>
10.1	Safety information.....	49
10.2	Disassembly .....	50
10.3	Disposal .....	50

## General

### 1.1 Information on these operating instructions

These operating instructions contain important information on handling the device during installation, operation, maintenance and care as well as disposal.

The compliance with all specified safety information and instructions is a requirement for a safe, intended and efficient work on and with the device.

Their observance helps avoid dangers, reduce repair costs and down-times and increases the reliability and service life of the device.









In addition to these operating instructions, the scope of delivery of the device includes a type sheet as well as a circuit diagram showing all technical details and actual features of the delivered device. Furthermore, the relevant local regulations for the prevention of accidents and general safety provisions applicable to the site of application of the device must be complied with.

Read these operating instructions and accompanying documents carefully prior to beginning work! Keep these operating instructions and the accompanying documents in custody for a later use.

## 1.2 Explanation of the symbols

Warnings in these operating instructions are additionally identified by warning symbols.

These operating instructions use the following symbols:

Symbol	Meaning
	General warning
	Danger by electrical power
	Special dangers in explosion-protected areas
	Danger by pressurized plant sections!
	Danger caused by hot components or surfaces
	Special information on the use in hazardous locations
	Information on disposal
	General information and useful recommendations for handling

In addition, these operating instructions use the term heat-systems as an abbreviated name for the company „heat-systems GmbH & Co. KG Elektrowärme-Technik“.

## 1.3

### Warnings

The warnings used in these operating instructions are preceded by signaling words specifying the extent of danger.

In addition, the warning symbol identifies the type of danger.

These operating instructions use the following warnings:

	<b>⚠ DANGER</b>
	<b>Lethal danger!</b> Consequences in case of non-compliance... ▶ Information on avoidance

A warning of this danger level identifies an imminently dangerous situation.

If the dangerous situation is not avoided, this will result in death or severe injuries.

Observe the instructions in this warning to avoid a lethal danger or severe injuries to persons.

	<b>⚠ WARNING</b>
	<b>Danger of injuries!</b> Consequences in case of non-compliance... ▶ Information on avoidance

A warning of this danger level identifies a possibly dangerous situation.

If the dangerous situation is not avoided, this will result in death or severe injuries.

Observe the instructions in this warning to avoid a lethal danger or severe injuries to persons.

	<i>ATTENTION</i>
	<p><b>Property damage by...</b> Consequences in case of non-compliance... ▶ Information on avoidance</p>

A warning of this danger level identifies a possible property damage.

If this situation is not avoided, property may be damaged.

Observe the instructions in this warning to avoid property damage.

	<i>NOTE</i>
	<p>Note text...</p>

A note identifies additional information which is important for further procedures or facilitates the working step described above.

## 1.4 Limitations of liability

All information in these operating instructions were compiled on the basis of the applicable standards and regulations, the state of the art and our long-standing knowledge and experience.

We reserve the right to technical modifications within the scope of a further development of the device described in these operating instructions.

Claims cannot be put forward from the information, figures and descriptions in these operating instructions.

*heatsystems* shall not be liable for damage and operating faults due to:

- Non-compliance with these operating instructions;
- Improper use;
- Use of untrained or insufficiently trained personnel;
- Use of improper operating resources and auxiliary material;
- Use of inadmissible fluids;
- Faulty connections;
- Preceding work not included in the scope of deliveries and services;
- Non-use of original spare parts and accessories;
- Technical modifications or reconstructions not agreed with *heat systems*;
- Non-execution of specified maintenance work;
- Overheating of the heating elements by a wrong flow direction of the fluid in the process heater or the formation of deposits;
- Overheating of the connection housing by a thermal insulation of the cooling section;
- Removal of the temperature indicator in the connection housing;
- Mechanical damage caused e. g. by improper cleaning; and
- Damage caused by corrosion.

*heatsystems* shall be liable for possible faults or non-performances by us within the scope of the contractual warranties, excluding further claims. Claims for damages shall be excluded, regardless of their legal basis.



## 1.5 Copyright

This documentation is copyrighted.

All rights, even to copying, reproduction and the distribution by special processes (e.g. data processing, data medium and data networks), wholly or partially, as well as to modifications to the contents and design are reserved.

## 1.6 Manufacturer's data

heatsystems GmbH & Co. KG  
Elektrowärme-Technik  
Am Höhmelskopf 8  
D-51580 Reichshof / Wehnrath  
Phone: (+49) 02265-9970-0  
Fax: (+49) 02265-997070  
e-Mail: [info@heatsystems.de](mailto:info@heatsystems.de)  
Web: [www.heatsystems.de](http://www.heatsystems.de)

## 1.7 Customer service

If you have any technical questions about the device, do not hesitate to contact *heatsystems*.

In such a case please provide the following information:

- Device identification and type of the device
- Year of construction
- Serial number

The required information can be referred to on the nameplate of the device.

## 2

### Safety

This chapter contains important information on all safety aspects for an optimal protection of the personnel as well as the safe and proper operation.

In addition to the general safety information and information on special dangers in this chapter, each chapter contains the safety information relevant for a safe handling.

Dangers which may occur during a special working step are described before the respective step.

	<b>⚠ DANGER</b>
	<p><b>Lethal danger by non-compliance with the safety information.</b></p> <p>Non-compliance with the safety information in these operating instructions may cause lethal situations.</p> <ul style="list-style-type: none"><li>▶ Observe all warnings and instructions specified here.</li><li>▶ In case of a reference to other documents observe the safety information contained in them as well.</li></ul>

In addition, the country-specific installation standards (e.g. the VDE regulations in Germany) as well as the relevant safety regulations, directives on operational safety and the regulations for the prevention of accidents are applicable to the application of the device.

## 2.1 Proper use

The electrical process heater and/or flange heater is designed for heating fluids which are not subject to an explosion during operation. The electrical connections must be in the non-hazardous area or in Zone 1 and Zone 2 hazardous areas.

The admissible operating data as described on the nameplate or in the type sheet must be observed.

Another application or a use beyond that will not be deemed proper.

	<b>⚠ WARNING</b>
	<p><b>Danger caused by improper use!</b> In case of an improper use and/or another application of this device dangers or property damage may occur.</p> <ul style="list-style-type: none"><li>▶ Use the device exclusively for the purpose it is intended for.</li></ul>

	<i>NOTE</i>
	<p>The electrical process heater and/or flange heater is exclusively intended for an installation and a plant. Commissioning is prohibited until the entire plant complies with the regulations of the applicable EC directives.</p>

Claims of any type because of damage caused by an improper use shall be excluded.

The plant operator shall be responsible for the risk.

## 2.2

### Plant operator's responsibility

Since the device is used in industrial areas, the plant operator must meet the legal obligations with regard to occupational safety.

In addition to the safety information contained in these operating instructions, the safety, accident prevention and environmental protection regulations relevant for the operation of the device, and in particular the German Industrial Safety Regulation (BetrSichV), must be complied with.

The plant operator has to:

- inform himself about the relevant occupational safety regulations and identify additional dangers in a danger assessment resulting from the special working conditions at the site of the device;  
This information must be implemented in the form of operating instructions for the operation of the device.
- comply with the requirements of the site of installation;
- position suitable warnings at the site of installation, indicating dangers in the working area.
- check during the entire service life of the device whether the operating instructions prepared by the plant operators comply with the latest version of the codes and adapt them, if required;
- define the personnel's responsibility unambiguously for installation, operation, maintenance and cleaning;
- make sure that all employees working with the device have read and understood the operating instructions. In addition, the personnel must be trained and informed about the dangers in the working area at regular intervals;
- review the safety-conscious and danger-conscious work of the personnel regularly, taking account of the operating instructions;
- make sure that these mounting and operating instructions as well as all other relevant regulations are within the reach of the operating and maintenance personnel;
- review and document the compliance with the specified cleaning and maintenance intervals;
- provide the required protective equipment for the personnel.

## 2.3 Other applicable standards and regulations

Unless otherwise specified, the heater has been designed and constructed on the basis of the AD2000 Code and DIN EN 60079-0 and -1.

In addition, the following standards and regulations must be observed for the installation and operation of the device in the user's country.

- Ranking in the relevant category according DGR (97/23/EC)
- Ranking in the ATEX directive 94/9/EC and the BetrSichV (German Industrial Safety Regulation)
- If necessary, compliance with the TRbF (Technical Regulations for Combustible Liquids) and comparable technical codes

## 2.4 Prohibition of reconstructions

All reconstructions and modifications to the device are prohibited. *heatsystems* will not be liable for damage resulting from them.

## 2.5

### General safety information

The device complies with the general state of the art and has been designed and manufactured on the basis of all relevant regulations and directives.

Basically, the following safety information must be complied with for handling the device safely:

- Inspect the device regularly for obvious damage and defects; Replace or shut down a damaged device immediately;
- Have installation and/or maintenance work be performed by authorized technical personnel only;
- Safeguard the working area prior to beginning cleaning, maintenance or repair work;
- Observe the specified intervals for recurring reviews and inspections;
- Replace worn or defective parts with original spare parts only;
- Use suitable tools only;
- Replace all protective equipment after repairs and check their electrical and mechanical function;
- Keep the operating instructions within the personnel's reach at any time.

## 2.6

### Special dangers

#### 2.6.1

#### Operation in hazardous areas

The device meets the requirements according to the Directive 94/9/EC (ATEX 95) for an application in an explosion-proof area. The type test certificate can be requested from *heatsystems*.

	<b>⚠ DANGER</b>
	<p><b>Lethal danger by non-compliance with the safety information during operation in a hazardous area!</b></p> <p>Non-compliance with the special safety information and instructions in these operating instructions can cause lethal situations in a hazardous area.</p> <ul style="list-style-type: none"> <li>▶ Observe all warnings and instructions specified.</li> <li>▶ In case of reference to other documents observe the safety information contained in them as well.</li> </ul>

	<i>NOTE</i>
	<p>Information on the safety in hazardous areas are identified by the symbol on the left side.</p>

2.6.2

Danger by electricity

	⚠ DANGER
	<p><b>Lethal danger by electricity!</b> Lethal danger in case of a contact with live lines or components!</p> <ul style="list-style-type: none"> <li>▶ Never use the device if electrical lines or plugs are damaged. Perform checks at the intervals specified in the operating instructions for the recurring reviews/inspections.</li> <li>▶ Work on the electrical equipment must only be performed by an electrician or instructions persons under the supervision of an electrical expert according to the electro-technical regulations.</li> <li>▶ Defects identified on electrical systems, modules, operating resources must be eliminated immediately. If there is a real danger at that time, the system, module or the operating resources must never be used in their improper condition.</li> <li>▶ Device parts where inspection, maintenance and repair are performed must be de-energized. Check the de-energized parts for absence of power first. Then, earth and short-circuit them as well as neighboring live parts, insulation!</li> <li>▶ If work on live parts is necessary, call another person who actuates the main switch with shunt tripping in case of emergency. Cordon off the working area, using a red-white restriction chain and a warning sign. Use voltage-insulated tools only!</li> </ul>

2.6.3

Danger of burning

	⚠ WARNING
	<p><b>Danger of burning on hot surfaces!</b> The surface of the device and connection</p>



	<p>housing can be very hot during operation.</p> <ul style="list-style-type: none"><li>▶ Wear suitable protective clothing.</li><li>▶ Let the device and/or plant cool down prior to beginning work.</li></ul>
--	--

## 2.6.4

### Danger by pressurized plant sections

Whenever the device is used in pressurized plants, there is additional danger by pressurized plant sections.

	<p><b>⚠ WARNING</b></p>
	<p><b>Danger by pressurized plant sections!</b></p> <p>If the device is operated in pressurized plants, pressurized plant sections may result in dangers.</p> <ul style="list-style-type: none"><li>▶ Let the device and/or plant cool down.</li><li>▶ Depressurize pressurized facilities completely!</li><li>▶ Check, prior to beginning the work, whether the pressure has been removed completely!</li></ul>

## 2.7

### Safety devices

The device is optionally equipped with a temperature sensor, temperature limiter or an overheating protection. The associated sensors are contained in an immersion tube which protrudes to the medium to be heated through the tube plate and is surrounded by it. The exact design can be referred to in the type sheet.

The sensor may be positioned such that either the fluid temperature or the temperature of the heating surface is measured.

All temperature sensors can be a capillary thermostat, resistance temperature sensor or thermocouple. The respective shut-off temperature is pre-adjusted.

During commissioning the switching point may require a re-adjustment, in particular to ensure the retention of a maximum surface or fluid temperature.

	<b>ATTENTION</b>
	<p><b>Property damage by overheating</b></p> <p>If the maximum values as specified in the type sheet are exceeded, the device may be damaged by overheating.</p> <ul style="list-style-type: none"><li>▶ Select the switching points such that the maximum values as specified in the type sheet are not exceeded.</li></ul>

In addition, the connection housings are optionally equipped with a separate temperature sensor as a housing over-temperature protection.

## 2.8

### Requirements for the personnel

	⚠ DANGER
	<p><b>Lethal danger in case of insufficient qualification!</b></p> <p>Improper work on and with the device may result in considerable damage to persons and property.</p> <ul style="list-style-type: none"> <li>▶ All activities must be performed only by persons who are qualified for that.</li> <li>▶ Observe the regulations applicable to the age and profession when selecting the personnel for the application site of the device.</li> </ul>

These operating instructions specify the following qualification for different activities:

- **Instructed person**  
was instructed by the plant operator in the entrusted task and possible dangers in case of improper behaviour.
- **Skilled person**  
can, due to its professional training, knowledge and experience as well as familiarization with the relevant regulations in hazardous areas, perform the entrusted works and tests as well identify and avoid possible dangers by itself.
- **Expert personnel**  
can, due to its professional training, knowledge and experience as well as familiarization with the relevant regulations, perform the entrusted works and tests as well identify and avoid possible dangers by itself.
- **Electrician**  
can, due to its professional training, knowledge and experience as well as familiarization with the relevant standards and regulations, perform the entrusted works and tests as well identify and avoid possible dangers by itself.  
The electrician has been trained for the special site of application and knows the relevant standards and regulations.



Only persons who can be expected to do their work reliably are admitted as personnel. Persons whose capability of reaction is influenced by e.g. narcotics, alcohol or drugs are not admitted. Personnel to be trained, to be trained initially, to be instructed or being educated generally may work on the machine only under the continual supervision of an experienced person.

## 2.9 Personal protective equipment

The personnel must wear the protective clothing as specified by the plant operator for the site of application of the device during all work on the device.

	<b>⚠ WARNING</b>
	<p><b>Danger of injuries by wrong or missing protective equipment!</b></p> <p>The work requires that personal protective equipment be worn to minimize dangers to the health.</p> <ul style="list-style-type: none"><li>▶ Always wear the protective equipment as specified by the plant operator during the work.</li><li>▶ Replace worn or defective protective equipment immediately.</li><li>▶ Observe the information on personal protective equipment in the working area.</li></ul>

### 3 Technical data

The technical data and details on the design of the device can be referred to on the respective nameplate, the type sheet and the circuit diagram.

The type sheet and the circuit diagram are part of these operating instructions.

#### 3.1 Storage conditions

Unless otherwise specified, the device must be stored in a dry and clean place complying with the environmental conditions below:

Storage temperature range	-30 ... +50 °C
Max. air humidity (non-condensing)	85 %

	<i>ATTENTION</i>
	<p><b>Property damage by wrong storage</b>                  Optionally, the device is delivered in a long-term packing (humidity-resistant with drying agent).                  If the device is stored for more than 3 months, check the general condition of the device and packaging regularly. If required, refresh or renew the conservation.</p>

## 4 Structure and function

The design and the construction of *heatsystems* products use the latest computer-based technologies which were selected to provide the optimum model and performance for the respective application. Optimization is made on the basis of the film temperature.

### 4.1 Electrical flange heater

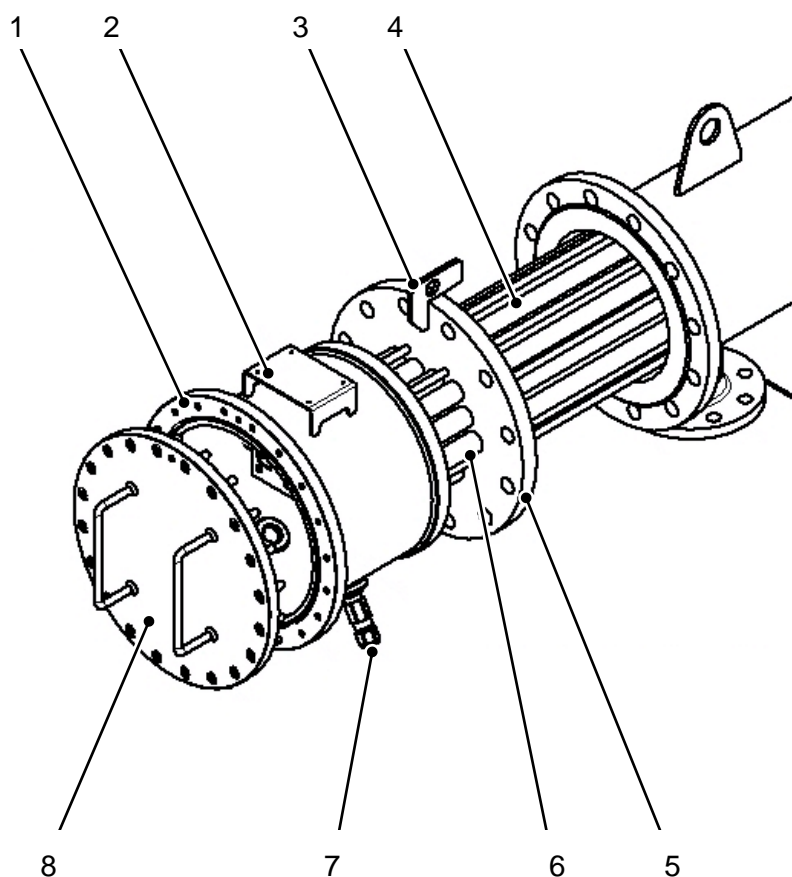

- |   |                         |   |                           |
|---|-------------------------|---|---------------------------|
| 1 | Connection housing      | 5 | Tube plate                |
| 2 | Flange heater nameplate | 6 | Cooling section optional) |
| 3 | Lifting plate           | 7 | Cable gland               |
| 4 | Heating surface         | 8 | Connection housing        |

### Connection housing

All electrical connections are contained in the connection housing. Cable glands are attached to the connection housing for entering the feeders into the connection housing.

<i>NOTE</i>	
	The connection housing has been designed for use in hazardous locations. Work on the connection housing must be performed by qualified expert personnel. Observe the specifications of DIN EN 60079-14 for the selection of the cable glands.

Depending on the design (not for explosion-protected devices), the connection housing has a pressure compensation element to prevent the formation of condensate water in the connection housing.

### Heating surface

The heating surface consists of heating elements which may be designed as highly compacted tubular heaters, rod-shaped cartridge heaters or oval tube heaters.

The material, dimensions and the length are customized to the application. Depending on the immersion depth and the fluid to be heated, the optimally suitable heater is determined.

<i>NOTE</i>	
	A possibly different length of the individual heating elements is due to the technology and has no influence on the quality or the performance of the heating elements.

### Tube plate

The tube plate is designed for accepting the heaters and fastening the flange heater to the container.

Dimensions according to EN 1092-2, form A, as a normal design. Other designs are possible according to customer's specifications.

### Cooling section

The section between the connection housing and the tube plate (cooling section) is sized such that the temperature in the connection housing has no detrimental effect on the terminals and the possibly installed closed-loop or open-loop elements.

The cooling section must not be insulated; otherwise, the temperature in the connection housing may rise to values which destroy the installed equipment. For control the connection housing contains an irreversible temperature indicator which keeps the maximum temperature reached in the connection housing. The temperature indicator must not be removed.

	<i>NOTE</i>
	The warranty will be null and void for property damage caused by overheating the connection housing or a removal of the temperature indicator.

### Temperature sensor

Depending on the design, the connection housing has a temperature sensor installed in it. The desired temperature can be set on a scale.

### Temperature limiter/overheating protection

The temperature limiter and/or the overheating protection are optionally installed in the connection housing.

The temperature limiter protects the medium or the container; the over-temperature protection protects the heating surface from too high a temperature.



#### **Heater in the connection housing**

If the flange heater is used at low ambient temperature, condensate water by dewing may form within the connection housing. To avoid dewing in the connection housing, the heater can optionally be integrated in the connection housing.

#### **Fan in the connection housing**

Depending on the design (not for explosion-protected devices), a fan can optionally be integrated in the connection housing to prevent the connection housing from overheating.

## 4.2 Electrical process heater

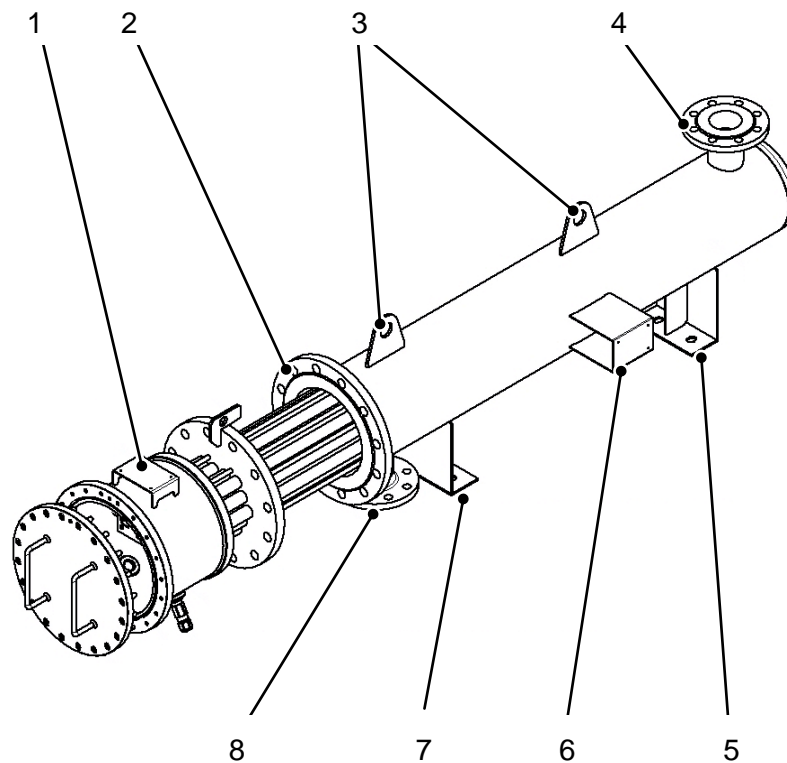

- |   |                          |   |                          |
|---|--------------------------|---|--------------------------|
| 1 | Electrical flange heater | 5 | Mounting base            |
| 2 | Container flange         | 6 | Process heater nameplate |
| 3 | Lifting plates           | 7 | Mounting base            |
| 4 | Fluid outlet             | 8 | Fluid inlet              |

### Container flange

For mounting the electrical flange heater to the container

### Lifting plates

Fastening points for lifting the process heater by suitable hoists

### Mounting bases

For fastening the process heater

### Fluid inlet/fluid outlet

The flow through the process heater should be away from the electrical connection housing to avoid a discharge of the gases entrained in the liquid. Otherwise, the heating elements may be overheated.

For liquid fluids the fluid inlet must be from the bottom and the fluid outlet to the top so that the container can be vented automatically. Otherwise, possibly separated gas bubbles may accumulate in the container and result in an overheating of the heating elements.



#### NOTE

The warranty will be null and void for property damage caused by a wrong flow through the process heater.

## 4.3

### Scope of delivery

The scope of delivery depends on the type and the design of the device. Refer to the accompanying documents for details on the scope of delivery.

## 5 Transport, packaging and storage

### 5.1 Transport inspection

The device is delivered including the components specified in the chapter "Scope of Delivery" as a standard.

	<i>NOTE</i>
	<p>Check the delivery for completeness and visible damage immediately after reception. Inform the supplier immediately of an incomplete or damaged delivery.</p> <p>If the device is not installed immediately after delivery, it must be stored properly (refer to the chapter "Storage") for information.</p>

	<b>⚠ WARNING</b>
	<p><b>Danger of injuries by a damaged device!</b></p> <p>A damaged device may cause dangers which result in injuries.</p> <p>▶ Never put a damaged device into operation.</p>

## 5.2 Packaging

Products from *heatsystems* are delivered in packagings which have been selected according to the type of shipment.

On request, the packaging can be a permanent packaging, e.g. for an extended storage as a spare part, or a seaworthy packaging.



### Disposal of the packaging

The packaging protects the device from transport damage. The packaging materials are selected according to environmentally friendly and disposable aspects and can therefore be recycled.

Returning the packaging to the material circulation saves raw material and reduces waste. Dispose of packaging materials no longer needed according to the local regulations.

## 5.3 Storage

Store the device and its accessories in the original packaging according the storage conditions as specified in the technical data for an extended storage prior to the installation or for spare parts storage.

	<b>ATTENTION</b>
	<p><b>Property damage by wrong storage</b></p> <p>In case of wrong storage moisture enters the device and causes damage. The magnesia incorporated in the heating elements as an electrical insulation is highly hygroscopic.</p> <ul style="list-style-type: none"> <li>▶ Observe the specified environmental conditions for storage.</li> <li>▶ When selecting the storage place, make sure that no large variations can be expected regarding the temperature and the air humidity.</li> </ul>

	<b>NOTE</b>
	<p>Moisture having entered the heating elements must be eliminated from them. If there are any questions about that, do not hesitate to contact <i>heatsystems</i>.</p>

## 5.4 Handling during transport

To avoid damage or leaks, observe the following during the transport of the device:

- Leave the device in its original packaging up to the site of installation.
- Use the lifting plates for lifting, if existing. Alternately, fasten the load suspension devices to the flange.
- Do not lift the device on the heating elements.
- When inserting the electrical flange heater, make sure that the heating elements are not exposed to shocks.

## 6 Installation

### 6.1 Safety information

Observe the following safety information when installing the device:

- Have the installation performed only by persons who are familiar with the activities to be performed and additionally have an appropriate qualification.
- Install the device such that it does not cause any danger, and no mechanical damage can affect it from the outside.
- Install the device such that the cable glands point downwards to prevent liquids from entering the connection housing through the cable glands.
- The device will be hot during operation. Take appropriate measures (e.g. thermal insulation) to make sure that there is no danger for people and the environment by the high surface temperature.

### 6.2 Requirements for the installation site

Observe the following information prior to the installation of the device.

- The device must only be installed according to the mounting position as specified in the type sheet.
- The container lead and return line should be provided with shut-off valves so that it is not necessary to drain the entire system in case of service.
- Make sure that the flow direction is such that it is preferably away from the electrical connection housing.
- In case of liquid fluids the inlet must be from below and the outlet to the top so that the container can be vented automatically. If the flow is in the opposite direction, the gases entrained in the liquid can be separated and cause an overheating of the heating elements. In this case warranty will be null and void.

- If the device is mounted in a tank (heating by convection), a minimum coverage of the heating surface and/or the heated surface of 100 mm must be ensured by appropriate measures (e. g. level monitoring).
- In case of fluids which can solidify the expansion of the fluid during heating must be taken into account. If an expansion is impeded, plant sections may be damaged or destroyed.  
**Recommendation:** Provide a "antifreeze heater" additionally.
- The thermal expansion of the fluid must be taken into account.
- Make sure during installation (fastening) and piping that the thermal expansion is not impeded. Otherwise, there will be excess mechanical stress which may damage the process heater of the plant.
- Make sure during installation that the electrical flange heater incorporated in the process heater can be removed for revision and inspection purposes. The appropriate space must be planned between the electrical connection housing the obstacles in the disassembly direction.  
**Thumb rule:** The space requirement is approximately equal to the total length of the process heater.
- Provide sufficient space between the electrical connection housing and the obstacles in the removal direction during the installation of the electrical flange heater in a container so that sufficient space is available for the installation and removal of the electrical flange heater.
- The heating element may be switched only if a sufficient heat absorption (flow) is ensured. If necessary, a flow with a locked load must be ensured by relief valves (or the like).  
**Recommendation:** Monitor the flow with a flow switch or another appropriate device.



- In case of flow devices let the fluid flow through the container for at least another 2 - 3 minutes after a deactivation of the heater to dissipate the energy stored in the heating elements.
- In case of a tank heater the rate of fall of the fluid must be selected such that the heater has cooled down to an undangerous rate before it emerges from the liquid.
- Install suitable safety valves against an overrange of the maximally admissible operating pressure. The safety valves must not be blocked by the container.
- Install branches of the safety valves such that the escaping fluid can be discharged safely.
- In pressure overlay systems a pressure gauge must be installed for indicating and/or reviewing the current operating pressure.
- If the operating pressure is above the boiling point of the fluid at atmospheric pressure, non-monitored systems must be provided with a pressure sensor which deactivates the heater in case of an insufficient pressure.  
**Recommendation:** Provide an indicator of the fluid temperature near the process heater.
- Use the device preferably on the pressure side of the pump. In case of an operation on the suction side make sure that the fluid outlet temperature is at least 15 K below the boiling temperature of the fluid pressure on the suction side.

## 6.3

### Mounting the electrical flange heater

Proceed as follows for installing the electrical flange heater:

- ▶ Clean the sealing surfaces of the electrical process heater and the container and/or the electrical process heater prior to installation.
- ▶ Insert the electrical flange heater with a flange seal into the container and/or electrical process heater and screw them finger-tight.
- ▶ Tighten the screws crosswise, using the rated moment.

	<i>NOTE</i>
	The tightening moment of the screws must match the sealing used and the type and design of the screws. If there are any questions about that, do not hesitate to contact <i>heat-systems</i> .

## 6.4

### Mounting the electrical process heater

Proceed as follows for mounting the electrical process heater:

- ▶ Position the electrical process heater on the site of application and use suitable screws for fastening the mounting bases to the floor.
- ▶ Pipe the process heater.

	<b>ATTENTION</b>
	<p><b>Property damage by wrong installation.</b> The container expands when heated. Damage to property may result from a wrong installation.</p> <ul style="list-style-type: none"><li>▶ Take account of the expansion of the container during installation.</li><li>▶ Do not apply inadmissible support forces.</li></ul>

	<b>NOTE</b>
	<p>If the corrosion protection is damaged during installation, eliminate the damage prior to commissioning.</p>

## 6.5

### Important information on the electrical connection

	⚠ DANGER
	<p><b>Lethal danger in case of insufficient qualification!</b></p> <p>A faulty connection of the device may result in situations threatening life.</p> <p>▶ Have the device connected by an electrician only.</p>

- The connection must be made according to the circuit diagram. The circuit diagram is glued in the connection housing.
- The protection elements must be installed according to the rated current. The power consumption in a cold condition is max. 5% above the rated load operating temperature.

	NOTE
	<p>Also, observe the regulations of DIN EN 60079-14 for an application in hazardous locations.</p>

#### Version with cable bushings



- The cables have already been connected in the connection housing. A terminal box of the type of protection as allowed by DIN EN 60079-0 can be used for a transition to the customer's supply network.

### Monitoring devices

- Integrate devices installed in the connection housing such as temperature sensors, temperature limiters and overheating protection into the control current circuit such that the power supply to the heater is interrupted whenever the set temperature is exceeded. Overheating protecting elements are thermally coupled to the first heating stage.
- If there are other heating stages, they must be electrically interlocked against their first heating stage.
- Make sure that the first heating stage is always activated before the other heating stages. This is not always ensured if a power controller selects several stages. In this case several overheat protection thermostats must have been installed, if necessary.

### Connecting terminals

- Tighten the connecting terminals, using the required tightening moment.
- Check after a month whether the connections have come loose. If the connections have come loose, retighten the terminals to make sure that increased transfer resistances cannot occur. These transfer resistances may destroy the connecting terminals and thus damage the entire heater.

### Cable glands



- Select the cable glands according to DIN EN 60079-14.
- Prepare and connect the cables according to the instructions for the cable glands.
- Screw in the cable glands, using the specified tightening moments.
- Close threaded bushings not required, using suitable blanking plugs. Secure the blanking plugs against rotation.

## 6.6

### Mounting the housing cover

	<i>NOTE</i>
	<p>The connection housing has been designed for use in hazardous locations.</p> <p>► Observe the following information on the installation of the housing cover to ensure proper operation in hazardous locations.</p>

- The "flame-proof enclosure"-type housing must not be opened unless it is made sure that there is no explosive atmosphere in the environment.
- The housing must be de-energized prior to opening.
- Check the joint surfaces of the flame-proof joint and the cover seal for damage. If the joint surfaces or the sealing are damaged, operation is prohibited.  
The device must be repaired by *heatsystems*.
- If no damage can be identified on the joint surfaces and the sealing, the cover may be mounted. Ensure that the cover is seated correctly.
- A suitable mounting paste (e. g. Weicon Anti-Seize) has been applied to the fastening screws for a protection from cold welding ("seizing"). Check the lubrication and renew it, if necessary.
- First of all, insert all screws (A2-70 quality) and tighten them loosely.
- Tighten all screws crosswise, using approx. 8-10 Nm.
- Finally, tighten all screws, using the rated tightening moment (M8: 16 Nm, M10: 35 Nm, M12: 50 Nm).

	<i>NOTE</i>
	<p>Tighten all screwed connections as specified.</p>

## 7

### Commissioning

	<b>ATTENTION</b>
	<p><b>Property damage by wrong commissioning.</b> In case of wrong commissioning the device may overheat and may be destroyed.</p> <p>► Observe all information contained here to avoid a destruction of the device.</p>

- Open all shut-off elements prior to activating the power supply. Fill the container with fluid and vent it. Fill the container slowly so that no damage caused by liquid hammerings can occur. The heating surface must always be covered by the fluid completely.
- Provide a sufficient flow for flow devices to make sure that the generated heat is dissipated by the fluid.
- Additional monitoring devices (level switches, flow monitoring) which ensure a sufficient transfer to the fluid are recommended. The electric control of the heater must be interlocked against these monitoring devices.
- Deactivate the power supply to the heater when the plant is tested (change of pump rotation).
- The monitoring devices must be adjusted by appropriately qualified persons to make sure that the required temperature class is complied with.



## 7.1 Setting/checking the operating points

### Temperature sensor

- If the device has a temperature sensor installed in the connection housing, the desired temperature may be set on a scale. The correct setting must be checked prior to commissioning.

### Temperature limiter/overheating protection

- The temperature set on the temperature limiter and/or the overheating must have a sufficient difference from the operating temperature.
- Make sure for devices wired in several switching steps that the overheating protection is electrically assigned to the first step. All other steps must electrically be interlocked against the first step.

### Mechanical thermostats

- When checking mechanical temperature detectors and temperature limiters, remember that they may have a differential (hysteresis) of up to 8 K and a system-related inertia.
- If the temperatures are below the admitted minimum values, capillary thermostats can deactivate themselves; as soon as the minimum is exceeded, they are activated automatically again.
- In case of very low currents (input to a PLC) faulty deactivations may occur. In this case the current must be increased via the contacts (general value 50 - 150 mA) - provide auxiliary contacts, if necessary.

### Switching steps

- The installed electrical power can be divided into several switching steps. The number of switching steps being in operation may be controlled as a function of the required energy.



## 7.2 Test run

Mounting, installation and commissioning must be followed by a test run for reviewing the proper function of all safety devices. The test run should be performed under the same conditions which can later be expected during normal operation.

<b>i</b>	<i>NOTE</i>
	After the test run retighten the screws of flange connection since the seal adapts itself to the flange due to the influence of the temperature.

## 7.3 Adjusting the overheating protection

The overheating protection is designed for identifying an overheating of the heating rod surface. Deactivating the heater before a critical temperature value is reached prevents damage to the heater.

The overheating protection is pre-set to a theoretically determined value in the factory. If the overheating protection is tripped before the desired temperature of the fluid is reached, the setting of the overheating protection must be modified.



Proceed as follows for setting the overheating protection during commissioning.

- ▶ First, adjust the overheating protection to the maximum value and heat the plant until the desired fluid temperature is reached.
- ▶ Lower the setting after approximately 15 minutes in the stationary condition until the overheating protection trips.
- ▶ Then, select a value approximately 20 K above the deactivation value for this setting. This ensures a quick response in case of a fault.

<b>i</b>	<i>NOTE</i>
	Due to the design, the overheating protection can monitor a small area of the heater surface only. Normally, the overheating protection cannot prevent an overheating of the heater over its entire surface, in particular if coats have been formed.

8

Maintenance/revision

 	<b>⚠ DANGER</b>
	<p><b>Lethal danger in case of an insufficient qualification of the personnel!</b></p> <p>Maintenance/revision of the device may only be performed by specially trained expert personnel.</p> <ul style="list-style-type: none"> <li>▶ Only electricians may work on the electrical system.</li> <li>▶ Explosive atmosphere must not prevail in the working environment.</li> <li>▶ Observe the safety regulations valid for the working area.</li> </ul>

	<b>⚠ WARNING</b>
	<p><b>Danger by pressurized plant sections!</b></p> <p>Pressurized plant sections may be endangered by maintenance work.</p> <ul style="list-style-type: none"> <li>▶ Let the device and/or plant cool down.</li> <li>▶ Depressurize pressurized facilities completely!</li> <li>▶ Check prior to beginning the work whether the pressure has been removed completely!</li> </ul>

The plant operator must make sure that the device and the plant in which the device is installed is checked for contaminations and deposits at regular intervals (min. annually, or more frequently depending on the fluid or category).

- The deposits on the heating surface must be removed to make sure that the heating surface can transfer the generated heat to the fluid sufficiently. If the deposits are not removed, heat may concentrate and cause the heating elements to burn.
  
- If corrosion damage is identified, check whether the process heater can be used any longer. In case of doubt do not hesitate to contact *heatsystems*.

	<i>NOTE</i>
	The check prior to commissioning as well as the scope and intervals of the recurrent checks are based on the legal regulations, among others the German Industrial Safety Regulation (BetrSichV).

## 8.1 Removing the flange heater

Observe the following information when removing the flange heater:

- Switch off the power supply and secure it against reactivation.
- Depressurize the plant and drain it such that the flange heater is no longer covered by the fluid.
- Let the container in which the flange heater is installed cool down to room temperature.
- Open the connection housing and disconnect the connecting lines.
- Loosen the cable glands and pull the connecting lines out of the connection housing.
- Loosen the fastening screws on the tube plate and remove them, observing the overturning moment of the device to avoid damage.
- Pull the flange heater out of the container. Make sure that the connecting housing is not exposed to excessive mechanical stress; otherwise, the connection housing or the installed equipment may be damaged. If the connection housing or the installed equipment is damaged, a revision at *heatsystems* is necessary.

## 8.2 Removing deposits

Observe the following information when removing the deposits:

- Loose and muddy deposits accumulated in the lower part of the container and on the heating surface can be washed away.
- Deposits which cannot be removed by washing away must be removed mechanically or dissolved.

	<b>ATTENTION</b>
	<p><b>Property damage caused by wrong cleaning.</b> The heating elements may be damaged by wrong cleaning.</p> <ul style="list-style-type: none"> <li>▶ Make sure during cleaning that the heating elements are not damaged mechanically or by the cleaner.</li> <li>▶ Do not use agents containing hydrochloric acid for cleaning.</li> </ul>

## 8.3 Reinstalling the flange heater

The installation of the flange heater and the electrical connection are described in Chapter 6.

Observe the following information additionally when reinstalling the flange heater:

- Always use a new flange seal when installing a new flange heater.
- Clean the sealing surfaces of the container and the flange heater prior to installation.
- Check all safety-relevant components such as heating elements, temperature sensor, temperature limiter, overheating protection for damage prior to a reinstallation. If there are defects, replace the defective parts with original spare parts.

## 8.4 Replacing components

Installed components may only be replaced by original spare parts. They can be requested from *heat*systems; please specify the production number of the device (refer to the nameplate).

### 8.4.1 Stockkeeping of spare parts

We recommend that the following spare parts should be kept for each device:

- 1 flange seal

### 8.4.2 Replacing the temperature sensors, temperature limiters

If temperature sensors, temperature limiters, overheating protection are defective, they must immediately be replaced by original spare parts. Refer to the information in *Chapter 6.6 Mounting the cover!* Proceed as follows for a replacement:

- Switch off the power supply and secure it against reactivation.
- Observe the safety regulations in the hazardous area and open the connection housing.
- Disconnect the electrical connection of the unit to be replaced.
- Loosen the unit to be replaced mechanically and pull the unit out of the immersion tube.
- Mount the new unit in the reverse order and connect it.
- Refer to the information in *Chapter 6.6 Mounting the cover!*

### 8.4.3 Replacing the wiring/connecting terminals

If the wiring or the connecting terminals are damaged, they must immediately be replaced with original spare parts.

Use only materials which are designed for the temperatures in the connection housing.

Alternately, the electrical flange heater can be returned to *heat*-systems for a revision.

## 9 Elimination of faults

Fault	Possible cause	Action
Water in the connection housing	Condensate water accumulates (outdoor installation) by a cold-warm-change in the connection housing. Water mainly in the form of droplets in the connection housing. Larger quantities accumulate on the bottom.	Provide a switchgear cabinet heater or install a pressure compensation element.
Liquid in the connection housing	Leaks of the heating rods. The liquid in the housing is the heated fluid. Running traces can be identified on the connection side of the flange plate. Liquid on a connecting terminal escapes from a feeding line to the heating rod.	Switch off immediately. Depressurize the plant and replace the heating element as quickly as possible. A fault cannot be identified until a removal.
Heating elements make a cracking sound (above all during first heating)	The noise is no fault but always occurs during first heating and will disappear during operation.	No action required.
Temperature not reached.	Supply voltage too low	First of all, measure the correct supply voltage which must match with the specifications on the nameplate. 10% less supply voltage means 20% less power!
	Heating element(s) defective	If the fault occurs after some time of operation, first check whether the heating elements are in a proper condition. For example, use a clip-on ammeter for measuring the power consumption of all steps in an activated condition or the electrical resistance in a deactivated condition.
Temperature not reached.	Heat requirement higher than planned (e.g. summer - winter)	If the power consumption of the heating element is ok, the heat requirement is obviously



Fault	Possible cause	Action
		higher than the heating element can generate. Modify the operating point (lower flow) or install a more powerful heating element.
Heating element does not heat	Temperature limiter tripped	If the fluid temperature is significantly below the temperature as set on the limiter, it may be reset by pressing the unlocking button. If a trip limiter cannot be reset in a cold plant (room temperature), a mechanical fault exists; replace the limiter by a component of the same type.
	Ambient temperature too low	Due to their design, capillary thermostats are switched off at temperatures below approx. -10°C. If these temperatures (environment!) can occur, other temperature switches must be used for anti-freeze heaters (e.g. PT100 with evaluation electronics)
Electronic temperature controller shows 1999 (flashing)	Sensor break in the sensor line or wrong connection polarity	In case of PT100 sensors check first whether they have been connected properly. If necessary, reverse the two outer connections. The checking resistance is approx. 110 Ohms for PT 100 at 20 °C. In case of three-wire sensors same colours identify the same "end" of the sensor.
Control quality bad	Badly adjusted control system (e.g. sensor position and/or control parameter)	Perform a self-optimization for electronic controllers during commissioning. The controller will then determine optimized control parameters independently. In case of mechanical controllers an optimiza-

Fault	Possible cause	Action
		<p>tion must be made by an external control loop, if necessary. Please note: both the sensor and the heater have a certain inertia which can be within the range of minutes, in particular for the heater. A satisfactory control quality can only be achieved in stationary operation in most cases. In particular, quick changes of the operating point can satisfactorily be corrected at great expense (with regard to control and process technology) due to the inertia.</p>
<p>Thermostat seems to switch erroneously</p>	<p>Current via the contacts too low</p>	<p>If, for example, a thermostat is wired to a PLC input, the current via the contacts is normally too low. This is the reason why the oxide layer of the contacts is not cleaned and the thermostat seems to switch off. We recommend a current of at least 100mA over the contact. An auxiliary relay must be used for an evaluation with a PLC.</p>



## 10 Disassembly and disposal

### 10.1 Safety information

<b>⚠ DANGER</b>	
	<b>Lethal danger in case of insufficient qualification of the personnel!</b>
	The device may only be disassembled by specially trained expert personnel.
	<ul style="list-style-type: none"><li>▶ Only electricians may work on the electrical system.</li><li>▶ No explosive atmosphere must prevail in the working environment.</li><li>▶ Observe the safety regulations valid for the working area.</li></ul>

<b>⚠ WARNING</b>	
	<b>Danger by pressurized plant sections!</b>
	Pressurized plant sections may be endangered by disassembly work.
	<ul style="list-style-type: none"><li>▶ Let the device and/or plant cool down.</li><li>▶ Depressurize pressurized facilities completely!</li><li>▶ Check prior to beginning the work whether the pressure has been removed completely!</li></ul>

	<b>▲WARNING</b>
	<p><b>Danger of injuries by improper disassembly!</b> An improper disassembly may result in severe damage to persons or property.</p> <ul style="list-style-type: none"> <li>▶ Make sure that there is sufficient installation space prior to beginning the work.</li> <li>▶ Keep the workplace orderly and tidy! Components and tools lying on each other or around are sources of accidents.</li> <li>▶ Disassemble the components properly.</li> <li>▶ Wear the protective clothing required by the plant operator for the site of application of the device.</li> </ul>

## 10.2 Disassembly

Proceed as follows to disassemble the device:

- Deactivate the power supply and disconnect the feeder on the switchgear cabinet.
- Depressurize the plant and drain it completely.
- Let the plant sections to be disassembled cool down to room temperature.
- Open the connection housing and disconnect the connecting lines.
- Loosen the cable glands and pull the connecting lines out of the connection housing.
- Loosen the fastening screws on the tube plate and remove them,
- Pull the flange heater out of the container and dispose of it according to the local regulations.
- Disassemble the process heater.

## 10.3 Disposal

Observe the following when disposing of the device:

- Remove problematic deposits according to the local regulations.
- Dispose of the flange heater according to the local regulations.
- Sort the metals and plastics for recycling or scrapping.



## Bescheinigung der Konformität für Komponenten - Certificate of Conformity for Components

**Komponentenbezeichnung:** Anschlussgehäuse DN200d  
component description Connection housing  
DN200d

**EG-Baumusterprüfbescheinigung** BVS 11 ATEX E161 U  
EC-Type Examination Certificate

**Hersteller:** heatsystems GmbH & Co. KG  
manufacturer Am Höhmelskopf 8  
D-51580 Reichshof-Wehnrath

**Wir erklären in alleiniger Verantwortung, dass das bezeichnete Produkt die Schutzanforderungen gem. genannter Normen und Richtlinien erfüllt.**

We hereby declare in sole responsibility that the designated product fulfils the safety requirements of the mentioned standards and directives:.

**Angewandte Richtlinien- applied directives:** 94/9/EG ATEX

**Kennzeichnung - identification / labeling:**  II G Ex d IIC Gb

**angewandte harmonisierte Normen:** DIN EN 60079-0, DIN EN 60079-1  
applied harmonized standards EN 60519-1, EN 60519-2,  
DIN EN 60529

**angewandte sonstige Normen** AD2000-Regelwerk  
applied other standards

### Einschränkung:

Die bezeichneten Produkte sind ausschließlich zum Einbau in eine Anlage bestimmt. Die Inbetriebnahme ist solange untersagt, bis die Anlage den Bestimmungen der EG-Richtlinien entspricht. Diese Erklärung ist keine Zusicherung im Sinne des Produkthaftungsgesetzes.

### Restriction:

The mentioned products have to be mounted into a plant. It is prohibited to set into operation until the plant fulfils the needs of the EC-directives. This declaration is no guarantee in the sense of the product liability law.

Reichshof-Wehnrath, den 20.09.2012

  
Oliver Saam  
(Geschäftsführer)